

2010

The Graphic Action Game

DISCOVERY REPAIR MANUAL

CONFIDENTIAL

OPEN ONLY WITH CLEARANCE

GREEN

TRANSMISSION 1

Mission Control to U.N.S.C. Leonov
TCF...439...CD...FD..BWKE..DJR.I...
Begin transmission....

Greetings, Major. This is Commissioner Thomas Charles from the United Nations Space Commission. During your voyage aboard the Leonov to Jupiter, I'll be your contact here at Mission Control. Hope you have a smooth trip.

Well, now to the job at hand. As you know, on its maiden voyage ten years ago, the Discovery's crew disappeared and the abandoned ship has been orbiting Io, a Jovian moon, ever since. Our most recent data indicates that the Discovery's orbit is decaying and that without repairs the ship will crash into Io.

Your mission is to get the Discovery spaceworthy and out of Io orbit by repairing and powering systems' circuits — Life Support, Communications, Engines, and Reactor — and repairing and powering the HAL 9000 computer. Once HAL is up and running, you'll have his assistance in powering up other systems' circuits.

I'll be transmitting data to you from time to time during the mission but, except for that, you're on your own out there. Next transmission: telemetry. Commissioner Thomas Charles, United Nations Space Commission out.

End transmission....

TRANSMISSION 2

Mission Control to U.N.S.C. Leonov
FL...MAG...E2...ARAM...JE954..CB..AG
Begin transmission....

Major, we've got a time-sensitive situation here. The Discovery's orbit is gradually decaying and the ship is falling toward Io's volcanic surface. Computer projections show that increased orbital decay and circuit burnout are closely linked to sulfur storms generated by volcanic activity on Io. Keep an eye on your altimeter on the strategic viewscreen. It displays both orbital altitude and atmospheric disturbances on Io.

Next transmission: status indicators. Commissioner Thomas Charles, United Nations Space Commission out.

End transmission....

TRANSMISSION 3

Mission Control to U.N.S.C. Leonov

BOSI...WWA...DCA..SO..90...MMC..JOK

Begin transmission....

Major, prepare for briefing on the Discovery's status indicators. A schematic drawing of the Discovery covers the upper-third of the strategic viewscreen. The ship's circuits glow blue and red. Priority-blue circuits must be powered; priority-red circuits indicate a burned-out CTI (cryotronic interface) and must be repaired. A circuit that has been previously powered can burn out, forcing you to replace the burned-out CTI and repower the circuit. Keep scanning the schematic for trouble spots.

The systems' status and HAL indicators occupy the lower two-thirds of the strategic viewscreen. When the systems are down, the status indicator titles are red. As circuits are repaired and powered, the indicator areas begin to fill. When the systems are up, the status indicator titles strobe green.

Next transmission: powering system circuits. Commissioner Thomas Charles, United Nations Space Commission out.

End transmission....

TRANSMISSION 4

Mission Control to U.N.S.C. Leonov

RF....AMC...OC19...5493...MAG...659..

Begin transmission....

Major, prepare for briefing and image transmission on powering Discovery's systems' circuits — Life Support, Communications, Reactor and Engines. Briefing and image transmission on powering HAL circuits follows in later transmission. Refer to the Engineering Repair Card for circuit-powering procedure.

Note that all circuits on the schematic are alphacoded: Life-Support Circuits (L); Engine Circuits (E); Communications Circuits (C); Reactor Circuits (R); and HAL Circuits (H).

Your task is to accelerate the power spark through each CTI once and only once, connecting all the CTIs on the circuit path. When the circuit is powered, the CTIs and the circuit path strobe red. The strategic viewscreen will then appear. Note that unless the spark is constantly accelerated, voltage drain occurs and the spark slowly travels backward through the circuit path. Unless a circuit is correctly connected, it will not power up.

To power a system circuit: Move the scanner window to the circuit you want. When the scanner window is correctly positioned, the circuit's code will appear. Then call the circuit up on the viewscreen. The correct circuit is searched for and then displayed on the screen.

Move the power spark through the circuit path. Take care to avoid the flickering multicolored MFFs (magnetic flux fields). If an MFF hits a CTI while the spark is inside, the CTI burns out and must be replaced. If the spark passes through the same CTI more than once (except during voltage drain), the CTI burns out.

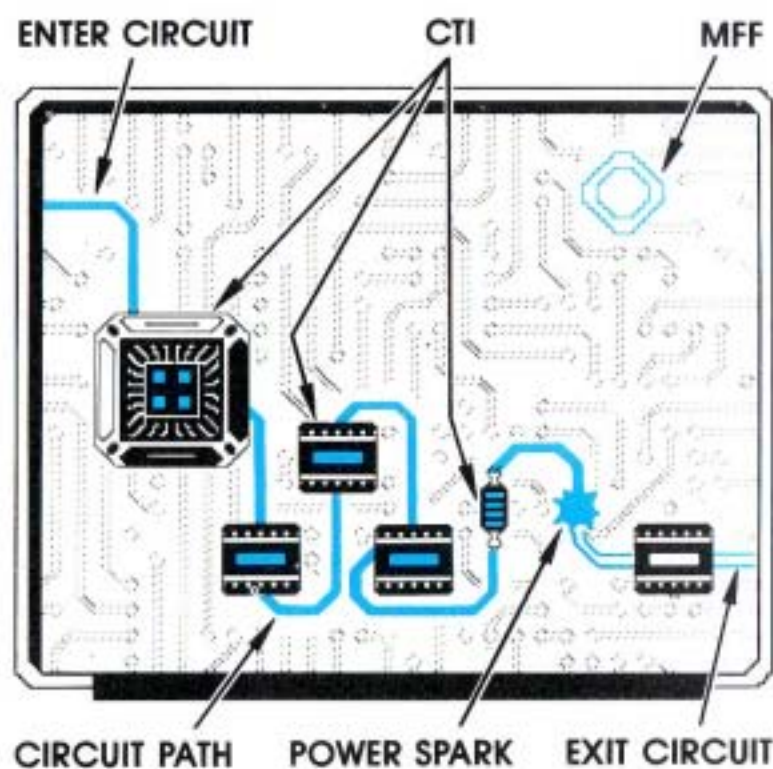

To replace a burned-out CTI, use WALDO, your shipboard repair drone. My next transmission will brief you on WALDO. Commissioner Thomas Charles, United Nations Space Commission out.

End transmission....

TRANSMISSION 5

**Mission Control to U.N.S.C. Leonov
CH01....RB.....276..NP....68JA9.LS2...
Begin transmission....**

Major, prepare for briefing on repair drone WALDO. With help from you, WALDO replaces any burned-out CTI. WALDO will appear on your viewscreen whenever a CTI needs replacement.

Image transmission....

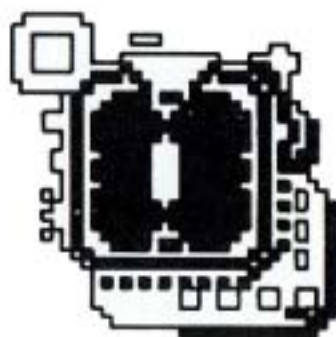

Move WALDO to the burned-out CTI. Check your Engineering Repair Card for hands-on procedures for using WALDO. You'll know WALDO's in place when the locking-in activator in its upper left-hand corner flashes blue and yellow. Cycle through WALDO's CTIs until you find one that matches the burned-out CTI. Then activate your choice. WALDO replaces the burned-out CTI and then disappears. The spark returns to the start of the circuit path. Begin powering the circuit again. WALDO replaces CTIs in both system and HAL circuits and can be used as often as needed.

Next transmission: HAL circuit powering. Commissioner Thomas Charles, United Nations Space Commission out.

End transmission....

TRANSMISSION 6

Mission Control to U.N.S.C. Leonov
GH....AF..JOB..67.TG.788..0MM..372....
Begin transmission....

Major, how's everything going? As noted in previous transmission, prepare for briefing and image transmission on powering HAL circuits. To access a HAL circuit, first move the scanner window to an H-coded circuit and call it up on your viewscreen. You'll note that HAL circuits are composed of both CTIs and CSIs (cryosynaptic interfaces). CSIs are HAL's artificial intelligence components.

Note that the CSIs are coded: **R** ; **I** and **B** . These codes direct the path that the pulse takes. **R** indicates a right turn on the circuit path; **I** lets the pulse go straight ahead on the path; and **B** bounces the pulse back to the previous CSI. To move the pulse through the circuit path, you'll have to change the CSI's coding during powering. Refer to your Engineering Repair Card for the explanation of code-change procedure.

Your task is to move the power pulse from the start of the circuit path to its exit by changing the coding inside the CSIs.

To power a HAL circuit, accelerate the pulse through the CSIs, changing the coding as the pulse speeds along the circuit path. Unlike system circuit powering, you do not have to connect each CSI. Note that unless the circuit is correctly connected, it will not power up.

Avoid passing the pulse through a CTI as this burns the CTI out and returns the pulse to the start of the circuit. If this happens, use WALDO to replace the burned out CTI.

If a MFF hits a CSI while the pulse is in it, it does not burn out. Instead the pulse returns to the circuit's entrance and you must start the powering job again.

Once you have the Life Support system up, HAL circuits are shielded. No MFFs appear in HAL circuits and HAL circuits do not burn out.

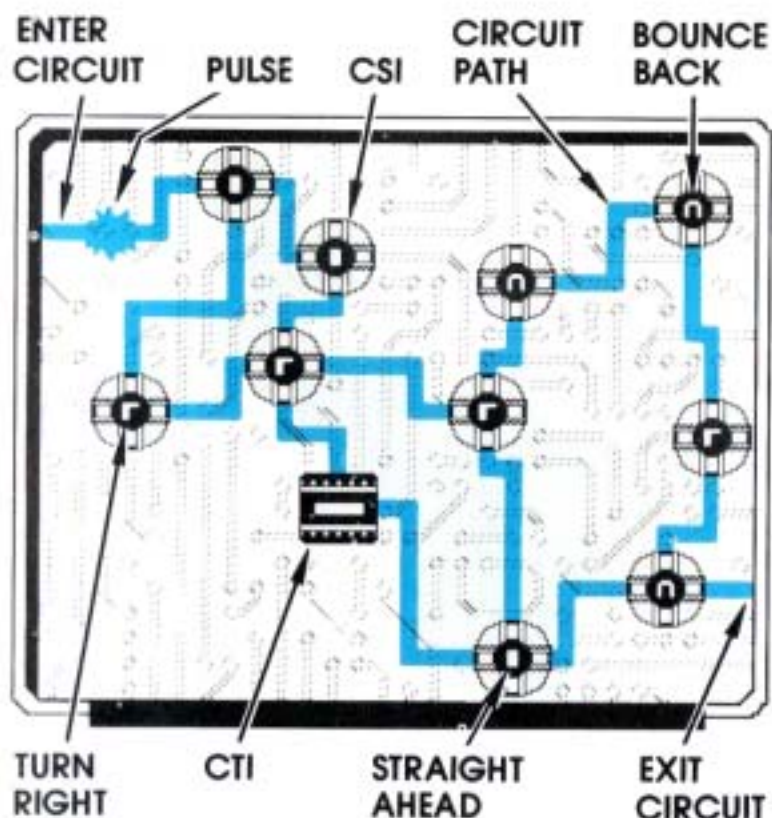

Next transmission: HAL-Assisted Circuit Powering. Commissioner Thomas Charles, United Nations Space Commission out.

End transmission....

TRANSMISSION 7

Mission Control to U.N.S.C. Leonov
PEG....SGI...SG....7650.21....GMC..6579
Begin transmission....

Major, prepare for briefing on HACP (HAL-Assisted Circuit Powering).

Once you have HAL up, he can assist you in powering other system circuits. Note that HAL can neither power up another HAL circuit nor can he repair a burned-out CTI. Move the scanner window to the system circuit you want to power, then activate HACP. Check the Engineering Repair Card for procedures. You'll see that a white dot appears inside the circuit that HAL's powering. If the Communication System is up, HAL sends messages across the

bottom of the viewscreen advising you of that circuit's status. Immediately call up another circuit and start repairing or powering that circuit yourself.

Next transmission: starting the engines and take-off. Commissioner Thomas Charles, United Nations Space Commission out.

End transmission....

EMERGENCY TRANSMISSION

**Mission Control to U.N.S.C. Leonov
EO...57839..BJAQ...PJT.....758393**

Begin emergency transmission....

Major, project engineers working on the Discovery simulator at Mission Control have come up with a partial-orbital boost maneuver that may buy you some more time. This maneuver is untested, except on the simulator, and should be used only as a last-ditch effort to save the Discovery. It's not without risks . . . this maneuver may be the biggest gamble of your life.

This is how the maneuver works: At any point in the mission when Engines and Reactor systems are up, you can try for a partial-orbital boost by pressing Start Engines. Watch the altimeter and then when you feel that you've gained enough altitude, press Start Engines again to turn the engines off.

If you've stopped the engines at the right time, you'll gain altitude without burning out any circuits. But if you've left them fire too long, you'll burn out circuits without any significant altitude gain, leaving you in an even more desperate situation.

Be warned that once you initiate partial-boost, you must let the engines cool. You cannot partial-boost again for 10 seconds.

We're with you, Major. Commissioner Thomas Charles, United Nations Space Commission out.

End emergency transmission....

TRANSMISSION 8

Mission Control to U.N.S.C. Leonov

PJ1....AB....2AC.GJMC.56..MP...4739...

Begin transmission....

Major, prepare for your final briefing. Hope all goes well and we'll see you Earthside soon.

To initiate engine start, look at your strategic viewscreen and do a final indicator check. The Reactor and Engine systems must be up to achieve even partial escape velocity from Io orbit. Remember that in some cases a partial boost may be enough for the Discovery to achieve escape velocity. Then press Start Engines (see Engineering Repair Card).

If you haven't powered or repaired enough circuits or if the Engine and Reactor systems aren't up, the engines fail and circuits burn out. You won't achieve escape velocity and may not be able to save the Discovery.

If you have repaired some circuits, the engines fire, giving you a partial boost in altitude and buying you time for a more complete repair job. Try this maneuver if you need a little more time to finish the mission.

If all systems are green, the engines fire; you achieve escape velocity and are homeward bound in a blaze of glory!

Good luck, Major. Commissioner Thomas Charles, United Nations Space Commission out.

Final transmission....

90-DAY LIMITED

Coleco warrants to the original consumer purchaser in the United States of America in the material and workmanship for 90 days from the date of purchase under normal use. This warranty is the sole and exclusive liability for defects in material and workmanship of the cartridge. Service Center. This warranty does not obligate Coleco to bear the cost of transportation. This warranty is invalid if the damage or defect is caused by accident, act of God or misuse.

Any implied warranties arising out of the sale of the cartridge including the implied warranty of merchantability are limited to the above 90 day period. In no event shall Coleco be liable to anyone for incidental, consequential, or punitive damages in connection with or arising out of the purchase or use of the cartridge. Moreover, Coleco shall not be liable for any claim of damages by any other party against the user of the cartridge.

This limited warranty does not extend to the programs contained in the cartridge. Coleco does not warrant the Programs will be free from error or will meet the specific requirements of the user. The user assumes responsibility for any decisions made or actions taken based upon information obtained from the Programs. The Programs are not to be construed as express or implied warranties.

Coleco makes no warranty, either express or implied, including any implied warranty of merchantability, in connection with the Programs, and all Programs are made available solely on an "as is" basis. In no event shall Coleco be liable to anyone for incidental, consequential, or punitive damages in connection with or arising out of the purchase or use of the Programs and the sole and exclusive liability, if any, of Coleco shall be limited to the price of the cartridge. Moreover, Coleco shall not be liable for any claim of damages by any other party against the user of the Programs.

This warranty gives you specific legal rights, and you may have other rights which vary from state to state. For limitations on how long an implied warranty lasts, see your state's laws.

SERVICE POLICY

Please read your Owner's Manual carefully before using your cartridge. If your cartridge malfunctions, please refer to the Operating Tips Manual. If you cannot correct the malfunction **after** consulting the Operating Tips Manual, please call our **hotline: 1-800-842-1225 nationwide**. This service is in operation from 8:00 a.m. to 5:00 p.m. Eastern Standard Time.

If Customer Service advises you to return your cartridge, please return it postage prepaid and a brief description of the problem to the Service Center you have been directed to. Within the first 90 days, it will be repaired or replaced at no cost to you. If the cartridge is not covered by the warranty, then you will be advised, in advance, of repair costs.

If your cartridge requires service after expiration of the 90 day Limited Warranty please call our **hotline: 1-800-842-1225 nationwide**.

IMPORTANT: SAVE YOUR RECEIPTS SHOWING DATE OF PURCHASE.

WARRANTY

Cartridge that the physical components of this cartridge will be free of defects for normal in-house use.

Cartridge shall be limited to repair or replacement at an authorized Coleco service center. Service charges in connection with the repair or replacement of defective parts.

Warranty does not cover consumer abuse, unauthorized alteration or repair, vandalism or misuse.

Warranty does not include implied warranties of merchantability and fitness for a particular purpose. Coleco does not warrant anyone for incidental, consequential, contingent or any other damages. However, Coleco shall not be liable for any claim of any kind whatsoever.

Programs and the accompanying documentation (the "Programs"). Coleco does not warrant the Programs or the performance or expectations of the consumer. The consumer assumes complete responsibility for the Programs obtained using the Programs. Any statements made concerning the utility of the Programs are made on an "as is" basis.

Warranty of merchantability and fitness for a particular purpose, in connection with the Programs, is hereby excluded on an "as is" basis.

Any claim for incidental, consequential, contingent or any other damages in connection with or arising out of the use of the Programs, regardless of the form of action, shall not exceed the purchase price of the Programs by any kind whatsoever by any other party against the user of the Programs.

Warranty varies from State to State. Some states do not allow the exclusion or limitation of consequential damages. If your warranty lasts, so the above limitations or exclusions may not apply to you.

POLICY

If your cartridge fails to operate properly, please refer to the trouble-shooting checklist in this manual. If you need further assistance, please call Customer Service on Coleco's **toll-free service** at 1-800-4-A-DAM, 10:00 p.m. Eastern Time, Monday through Friday.

Cartridge is prepaid and insured, with your name, address, proof of the date of purchase and return to. If your cartridge is found to be factory defective during the warranty period, it is found to have been consumer damaged or abused and therefore not covered by the warranty.

For more information during the warranty period, please call Coleco's toll-free service hotline for instructions on how to return your cartridge.

RETURNING DATE OF PURCHASE.

